

# Class 150 • Union Cap • Buna-N Disc • Threaded Ends

## Lift Check Valve Figure B-322B

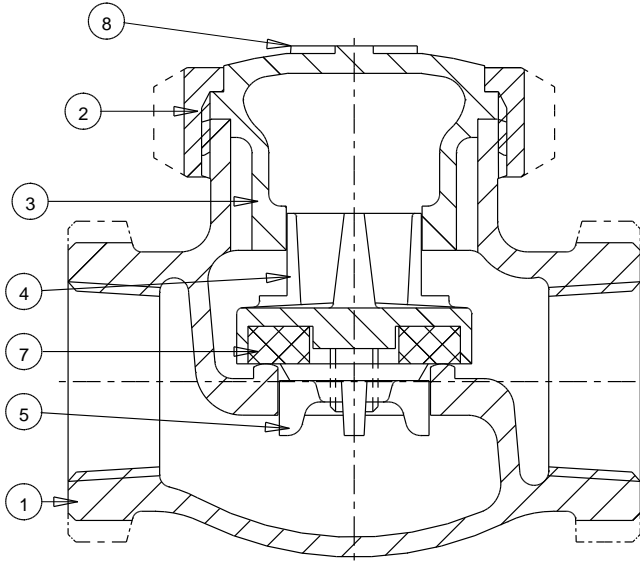

### Materials of Construction

No.	Description	Material	ASTM Spec.
1	Body	Bronze	B-62 C83600
2	Union Ring	Bronze	B-62 C83600
3	Cap	Bronze	B-62 C83600
4	Disc Holder	Bronze	B-62 C83600
5	Disc Retaining Nut	(1/4" - 3/8") Brass	BSEN 12164 CW614N
		(1/2" - 2") Bronze	B-62 C83600
7	Washer	(1/4" - 3/8") Brass	BSEN 12164 CW614N
8	Disc	Nitrile	

**NOTE:**

The addition of the letter "K" at the end of the figure number designates valves assembled & tested in the USA. Materials of Construction & Dimensions are the same.

### Industry Standards

Complies with MSS SP-80 Type 2

See Page 6 for Pressure-Temperature Ratings

### Dimensions and Weights

Inches (millimeters) - Pounds (kilograms)

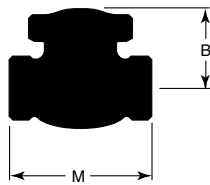

Valve Size	Dimensions		Wt.
	B	M	
1/4	1.46	2.32	0.82
	(37)	(59)	(0.37)
3/8	1.46	2.32	0.79
	(37)	(59)	(0.36)
1/2	1.69	2.68	1.13
	(43)	(68)	(0.51)
3/4	1.93	3.19	1.87
	(49)	(81)	(0.85)
1	2.21	3.74	2.91
	(56)	(95)	(1.32)
1 1/4	2.56	4.25	4.35
	(65)	(108)	(1.97)
1 1/2	2.87	4.76	5.84
	(73)	(121)	(2.65)
2	3.43	5.75	9.79
	(87)	(146)	(4.44)